

Step "A"

Step "B"

Step "C"

Step "D"

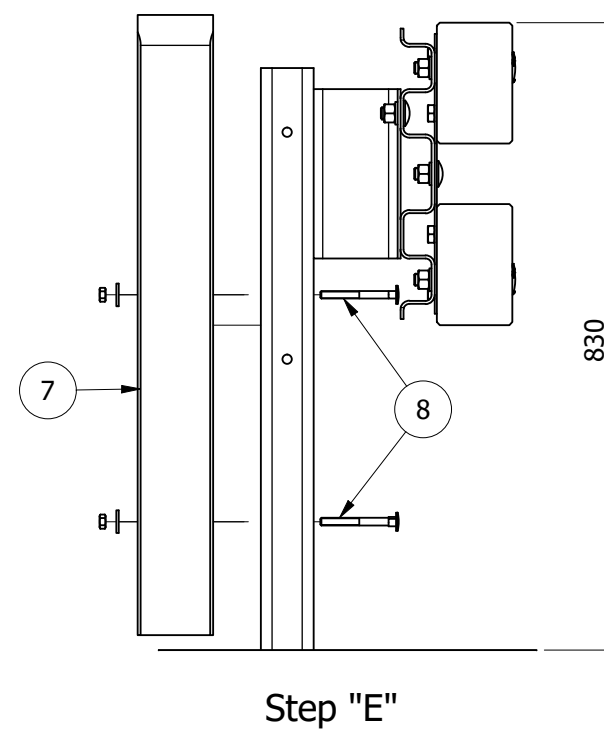
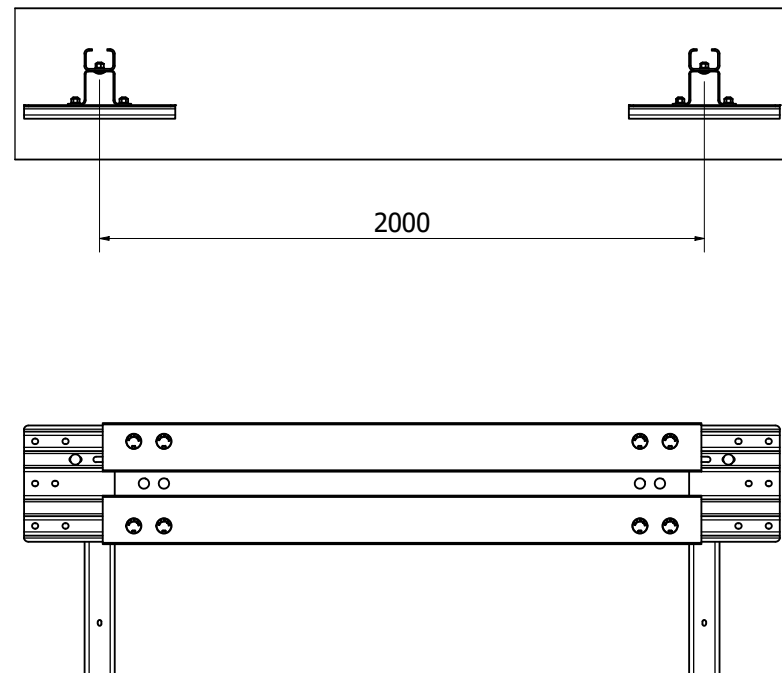

Step "E"

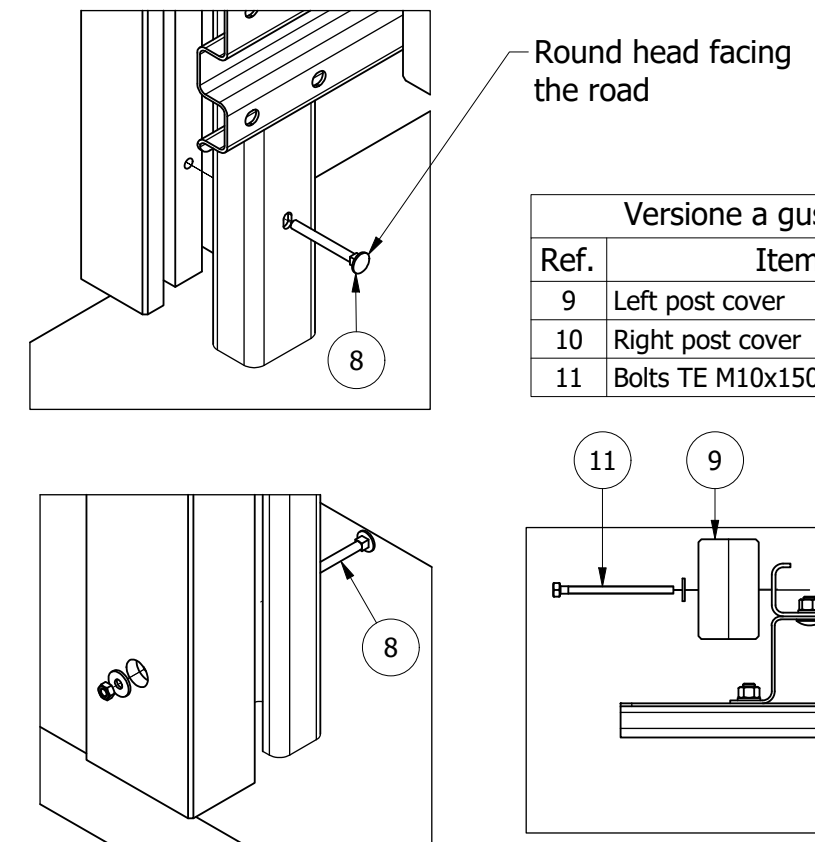

Versione a guscio doppio	
Ref.	Item
9	Left post cover
10	Right post cover
11	Bolts TE M10x150

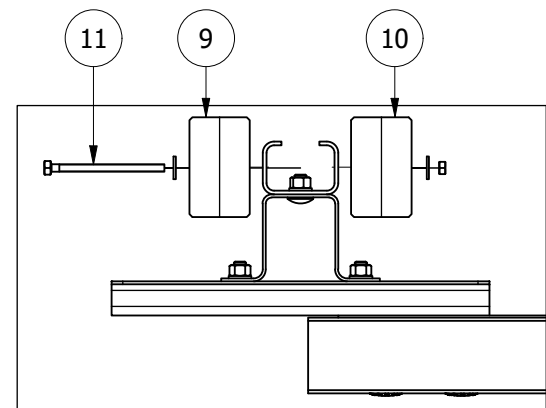

Measurements expressed in mm

Tightening torque:

Ref. 3 & 6 torque between 150 & 200 Nm

Torque values must be checked with a calibrated torque wrench
The bolts Ref. 6 are preassembled, remove the nuts to proceed with the installation

Component list	
Ref.	Item
1	"C" Post
2	Blockout
3	Bolts TT M16x30
4	Corrugated Splice Plate
5	Protection rail
6	Bolts TTQST M16x125
7	Single rear post cover
8	Bolts TTQST M10x100



MARGARITELLI
ROAD SAFETY

Drawing IM 002-01	Issued 26/06/2003
Review 07	Date 20/06/2022

Object: Road Side Safety Barrier H2BL-01
Certificate of Costancy of Performance CE n° 0497/CPR/3154
Assembly instructions