

Double cover version	
Ref.	Item
9	Left post cover
10	Right post cover
11	Bolts TE M10x150

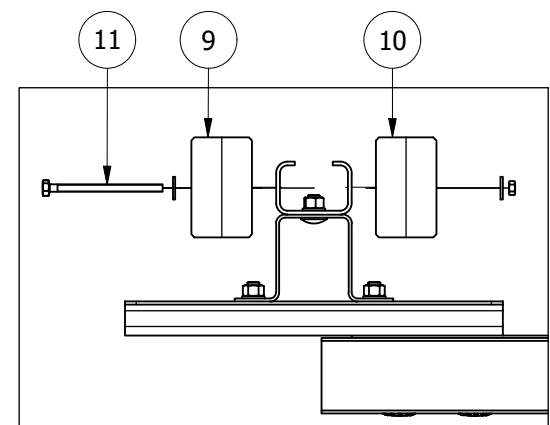

Measurements expressed in mm

Tightening torque:

- Ref. 3 torque between 120 & 130 Nm
- Ref. 6 torque between 150 & 200 Nm

Torque values must be checked with a calibrated torque wrench
The bolts Ref. 6 are preassembled, remove the nuts to proceed with the installation

Component list	
Ref.	Item
1	"C" Post
2	Blockout
3	Bolts TT M16x30
4	Corrugated Splice Plate
5	Protection rail
6	Bolts TTQST M16x125
7	Single rear post cover
8	Bolts TTQST M10x100



MARGARITELLI
ROAD SAFETY

Drawing IM 023-01	Issued 01/04/2008
Review 06	Date 20/05/2022

Object: Road Side Safety Barrier H1BL-01
Certificate of Costancy of Performance CE n° 0497/CPR/3152
Assembly instructions